

MED-CDPH89 SERIES

16GA MEDIUM SECURITY CORNER
MOUNTED WITH DROP HINGE HOUSING

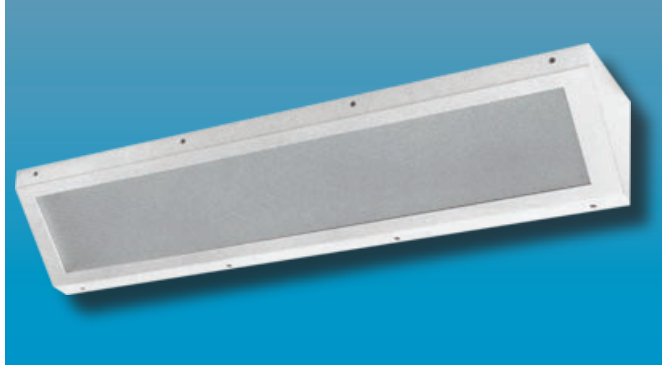

MEDIUM SECURITY

Specifier's Reference

Project Name	Type
Catalog No.	
Comments	

- **Listings/Certifications:** ETL (US/Canada)

Specifications

- **Housing:** 16ga cold rolled steel. Clamshell housing, all exposed seams continuous welded. Optional stainless steel housing and back plate available.
- **Back Plate:** One-piece, die-formed cold rolled steel, formed to provide an irretrievable contraband trap. Available in brushed stainless steel as option.
- **Fasteners:** Fully recessed, captive, center pin reject Allen head standard. Optional fasteners shown below.
- **Hinge:** Completely concealed, 16-GA, 1/4" diameter knuckle, continuous piano hinge with welded pin ends. Hinge welded to one-piece housing and bolted to back plate.
- **Lens:** Standard .125" thick clear prismatic acrylic with clear polycarbonate overlay. Optional lensing shown below.
- **Lens Retention:** Vertically adjustable "Z" shaped retaining angles secured with through studs and die-cast locknuts. Gauge to match housing.
- **Lamps:** See below for lamping options. Lamps supplied by others.
- **Ballasts:** Standard Class P, sound rated A electronic ballasts. Other ballast options available.
- **Finish:** Standard baked white polyester powder coat paint finish. Optional AgION™ antimicrobial finish available.

Ordering Information

Series	Size	No. Lamps	Lamp Type	Ballast Type	Lens Type	Fasteners	Options	Voltage
MED-CDPH89	- [] -	[] -	[] -	[] -	[] / []	[] -	[] -	[] -
	-4 4' Unit	-3 Three Lamps	-T8 4' 32W	-EB10IS Electronic Ballast	ENVIRONMENT SIDE	-F1 Allen Head - center pin reject, standard	-EMG1 1-Lamp Emergency Power Pak 500 Lumen initial output, 90 minute, 32° start temp.	-UNV
	-2 2' Unit	-2 Two Lamps	-T5 4' 28W 2' 14W	Instant Start <10% THD	-3 .250" Clear Polycarbonate	-SF Specified Fastener	-EMG2 2-Lamp Emergency Power Pak 1100 Lumen initial output, 90 minute, 32° start temp.	-347V
		-1 One Lamp	-T5HO 4' 54W 2' 24W	-SB Specified Ballast	-7 .250" Clear Tempered Glass		-SS Stainless Steel Housing, Brushed Stainless Steel Door	
					LAMP SIDE		-AG AgION™ Antimicrobial Protection in Powder Coat Paint	
					-A .125 Prismatic Acrylic		-PL7 7W PL Nightlight	
					-C .140 DR Prismatic Acrylic		-GLR GLR/HLR Fuse & Holder set	
					-G .156 Prismatic Tempered Glass		-WL Wet Location	
					-UV .007 UV Absorbing Overlay			

Note: Contact Factory For Additional Configurations.

MED-CDPH89 SERIES
 MEDIUM SECURITY CORNER
 MOUNTED DROP HINGE HOUSING



Dimensions & Mounting

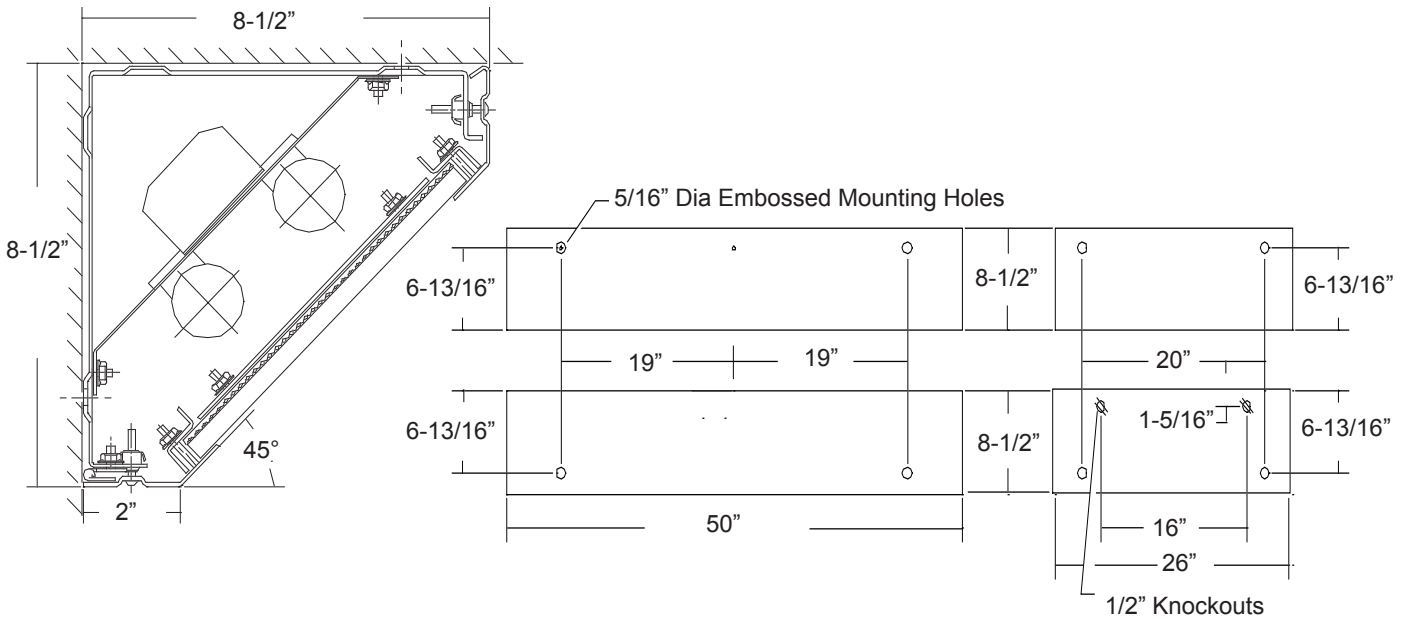

Photometry

Zonal Cavity Coefficient of Utilization
 I.T.L. Test No. ITL 37581,
 Product Catalog Number: MAX-CDPH-4-2
 Lamps: Two 32WT8, rated 3150 lumens.

Floor	20%										
Ceilings	80%			70%			50%				
Walls(%)	70	50	30	10	70	50	30	10	50	30	10
0	50	50	50	50	49	49	49	46	46	46	46
1	45	42	40	38	43	41	39	37	38	37	35
2	40	36	33	30	39	35	32	29	33	30	28
3	36	31	27	24	35	30	27	24	29	26	23
4	33	28	23	20	32	27	23	20	25	22	19
5	30	24	20	17	29	23	19	16	22	19	16
6	28	21	17	14	27	21	17	14	20	16	14
7	25	19	15	12	24	19	15	12	18	14	12
8	23	17	13	11	22	17	13	10	16	12	10
9	22	15	12	09	21	15	11	09	14	11	09
10	20	14	10	08	19	14	10	08	13	10	08

Candlepower Distribution

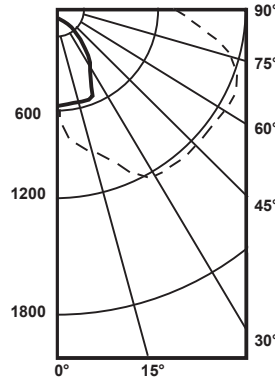

Average Luminance in Footlamberts

Average Brightness Vertical Norm Para Angles

45°	1798	639
55°	1816	515
65°	1837	498
75°	1786	389
85°	1571	142

Lumin. Effi.	Spacing Cross	Maint. Factor
43.1%	2.5	85%

Options

Antimicrobial: Agion™ Antimicrobial protection using silver technology inhibits bacterial colonization on metal interior and exterior surfaces. Agion™ antimicrobial FDA recognized and EPA registered, meeting all applicable EPA standards.



.125 Prismatic Acrylic Lens Standard

