

# MED-FH SERIES

MEDIUM SECURITY RECESSED FLANGE TROFFER

# MEDIUM SECURITY

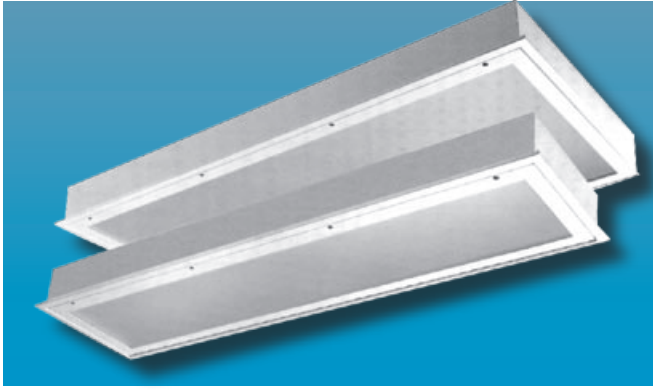

## Specifier's Reference

Project Name	Type
Catalog No.	
Comments	

- **Listings/Certifications:** ETL (US/Canada) listing

## Specifications

- **Housing:** 16 gauge, one-piece die-formed welded housing. Optional stainless steel housing available.
- **Door:** 16 gauge one-piece die-formed cold rolled steel. Available in brushed stainless steel as option.
- **Lens:** Standard .125" thick clear prismatic acrylic with clear polycarbonate overlay. Optional lensing shown below.
- **Lens Retention:** Vertically adjustable "Z" shaped retaining angles secured with through studs and die-cast locknuts.
- **Hinge:** 14 gauge 1/4" diameter knuckle, continuous piano hinge with welded pin ends. Hinge welded to housing and door.
- **Fasteners:** Fully recessed, captive, center pin reject Allen head standard.
- **Lamps:** See below for lamping options. Lamps supplied by others.
- **Ballasts:** Standard Class P, sound rated A electronic ballasts. Other ballast options available.
- **Finish:** Standard baked white polyester powder coat paint finish. Optional AgION™ antimicrobial finish available.
- **Mounting:** 14 gauge galvanized steel "U" channel mount accommodates various ceiling types and thicknesses. Additional mounting options shown below. Support above plenum by others. Optional plaster frame also available.

## Ordering Information

Example: **MED - FH - 24 - 6 - T5 - EB - 7/A - SS - UNV**

Series	Size	No. Lamps	Lamp Type	Ballast Type	Lens Type	Fasteners	Options	Voltage
<b>MED-FH</b>	-	-	-	-	-	-	-	-
	<b>-24</b> 2 X 4 Unit	<b>-6</b> Six Lamps (2X4 or 2X2 only)	<b>-T8</b> 2X4 32W 2X2 17W 1X4 32W	<b>-EB10IS</b> Electronic Ballast <10% THD Instant Start	<b>ENVIRONMENT</b> <b>-3</b> .250" Clear Polycarbonate (standard)	<b>-F1</b> Allen Head - center pin reject, standard	<b>-EMG1</b> 1-Lamp Emergency Power Pak 500 Lumen initial output, 90 minute, 32° start temp.	<b>-UNV</b> <b>-347V</b>
	<b>-22</b> 2 X 2 Unit	<b>-4</b> Four Lamps (2X4 or 2X2 only)	<b>-T5</b> 2X4 28W 2X2 14W 1X4 28W	<b>-SB</b> Specified Ballast	<b>-7</b> .250" Clear Tempered Glass	<b>-SF</b> Specified Fastener	<b>-EMG2</b> 2-Lamp Emergency Power Pak 1100 Lumen initial output, 90 minute, 32° start temp.	
	<b>-14</b> 1 X 4 Unit	<b>-3</b> Three Lamps (2X4, 2X2 and 1X4 only)	<b>-T5HO</b> 2X4 54W 2X2 24W 1X4 54W		<b>LAMP SIDE</b> <b>-A</b> .125 Prismatic Polycarbonate		<b>-SS</b> Stainless Steel Housing, Brushed Stainless Steel Door	
		<b>-2</b> Two Lamps (1X4 only)			<b>-C</b> .140 DR Prismatic Acrylic		<b>-AG</b> AgION™ Antimicrobial Protection in Powder Coat Paint	
					<b>-G</b> .156 Prismatic Tempered Glass		<b>-PL7</b> 7W PL Nightlight	
					<b>-UV</b> .007 UV Absorbing Overlay		<b>-GLR</b> GLR/HLR Fuse & Holder set	
							<b>-PF</b> Plaster Frame	
							<b>-WL</b> Wet Location	

Note: Contact Factory For Additional Configurations.

**Morlite**  
TOUGH SITES ..... TOUGH LITES

1805 Pittsburgh Ave, Erie, PA 16502 • 800-865-5954 • Fax 800-667-9959



**MED-FH SERIES**  
MEDIUM SECURITY RECESSED FLANGE



**Dimensions & Mounting**

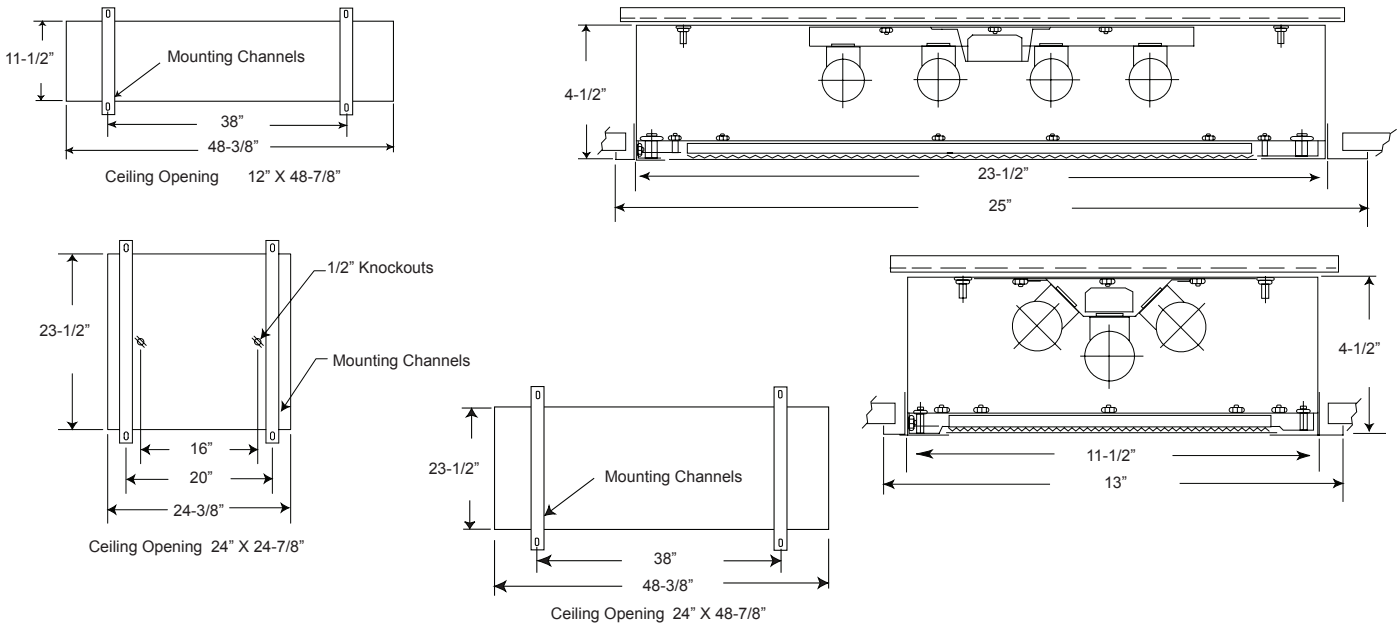

**Photometry**

**Zonal Cavity Coefficient of Utilization**  
I.T.L. Test No. ITL 37543, Product Catalog Number:  
MED-FH-24-F-4-T8-EB10IS-3/A-SSD-F1-UNV  
Lamps: Four 32WT8, each rated 3150

Floor Ceilings Walls(%)	80%				70%				50%			
	70	50	30	10	70	50	30	10	50	30	10	
0	69	69	69	69	67	67	67	67	64	64	64	
1	64	62	60	58	62	60	59	57	58	56	55	
2	59	55	52	49	58	54	51	49	52	50	48	
3	55	50	46	43	53	49	45	42	47	44	41	
4	51	45	40	37	49	44	40	37	43	39	36	
5	47	40	35	32	45	39	35	32	38	34	31	
6	43	36	31	28	42	36	31	28	35	31	28	
7	40	33	28	25	39	32	28	25	31	27	24	
8	37	29	25	21	36	29	24	21	28	24	21	
9	34	26	22	19	33	26	22	19	25	21	18	
10	31	24	19	16	31	24	19	16	23	19	16	

**Candlepower  
Distribution**

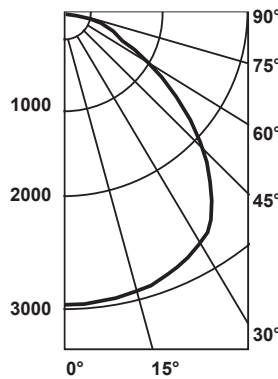

**Average Luminance  
in Footlamberts**

Vertical Angles	Average Brightness	
	Norm	Para
45°	1422	1185
55°	1101	931
65°	692	655
75°	482	452
85°	313	269

Lumin. Effi.	Spacing Cross	Maint. Factor
57.6%	1.4	85%

**Options**

**Antimicrobial:** Agion™ Antimicrobial protection using silver technology inhibits bacterial colonization on metal interior and exterior surfaces. Agion™ antimicrobial FDA recognized and EPA registered, meeting all applicable EPA standards.

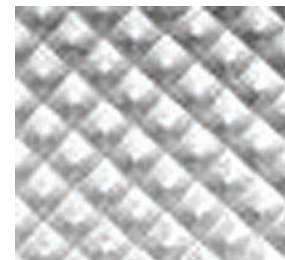

.125 Prismatic Acrylic Lens Standard

