

MED-WST45 SERIES
MEDIUM SECURITY WALL MOUNTED

MEDIUM SECURITY

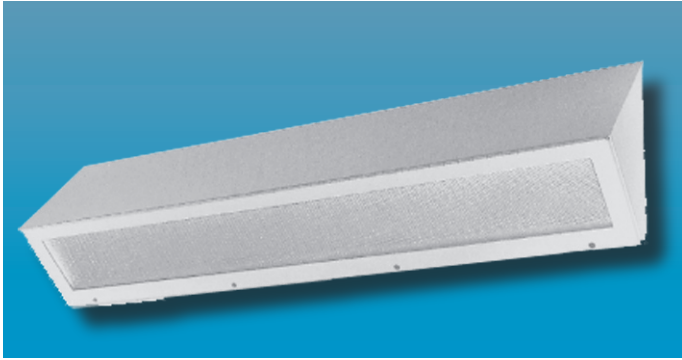

Specifier's Reference	
Project Name	Type
Catalog No.	
Comments	

- **Listings/Certifications:** ETL (US/Canada), damp location listed.

Specifications

- **Housing:** 16 gauge, die-formed welded housing. All exposed seams continuous welded. Optional stainless steel housing available.
- **Door:** 16 gauge one-piece die-formed cold rolled steel Available in brushed stainless steel as option.
- **Lens:** Standard .125" thick clear prismatic acrylic with clear polycarbonate overlay. Optional lensing shown below.
- **Lens Retention:** Vertically adjustable "Z" shaped retaining angles secured with through studs and die-cast locknuts.
- **Hinge:** 16 gauge 1/4" diameter knuckle, continuous piano hinge with welded pin ends. Hinge welded to housing and door.
- **Fasteners:** Fully recessed, captive, center pin reject Allen head standard.
- **Lamps:** See below for lamping options. Lamps supplied by others.
- **Ballasts:** Standard Class P, sound rated A electronic ballasts. Other ballast options available.
- **Finish:** Standard baked white polyester powder coat paint finish. Optional AglON™ antimicrobial finish available.
- **Installation:** See back page for installation details.

Ordering Information

Example: **MED - WST45 - 4 - 3 - T5 - EB10IS - 3/C - SS - UNV**

Series	Size	No. Lamps	Lamp Type	Ballast Type	Lens Type	Fasteners	Options	Voltage
MED-WST45	- []	- []	- []	- []	- []	- []	- []	- []
	-2 Nominal 2' Unit	-3 Three Lamps (4' only)	-BX 40W Biax (2' Unit Only)	-EB10IS Electronic Ballast <10% THD Instant Start	ENVIRONMENT SIDE -3 .250" Clear Polycarbonate (standard)	-F1 Allen Head - center pin reject, standard	-EMG1 1-Lamp Emergency Power Pak 500 Lumen initial output, 90 minute, 32° start temp.	-UNV -347V
	-4 Nominal 4' Unit	-2 Two Lamps	-T8 4' 32W 2' 17W	-SB Specified Ballast	-7 .250" Clear Tempered Glass	-SF Specified Fastener	-EMG2 2-Lamp Emergency Power Pak 1100 Lumen initial output, 90 minute, 32° start temp.	
		-1 One Lamp	-T5 4' 28W 2' 14W		LAMP SIDE -A .125 Prismatic Polycarbonate		-SS Stainless Steel Housing, Brushed Stainless Steel Door	
			-T5HO 4' 54W 2' 24W		-C .140 DR Prismatic Acrylic		-AG AglON™ Antimicrobial Protection in Powder Coat Paint	
					-G .125 Smooth White Polycarbonate		-PL7 7W PL Nightlight	
					-UV .007 UV Absorbing Overlay		-LEDNL LED Nightlight	
							-GLR GLR/HLR Fuse & Holder set	
							-PL7 7W PL Nightlight	
							-WL Wet Location	

Note: Contact Factory For Additional Configurations.

Dimensions & Mounting

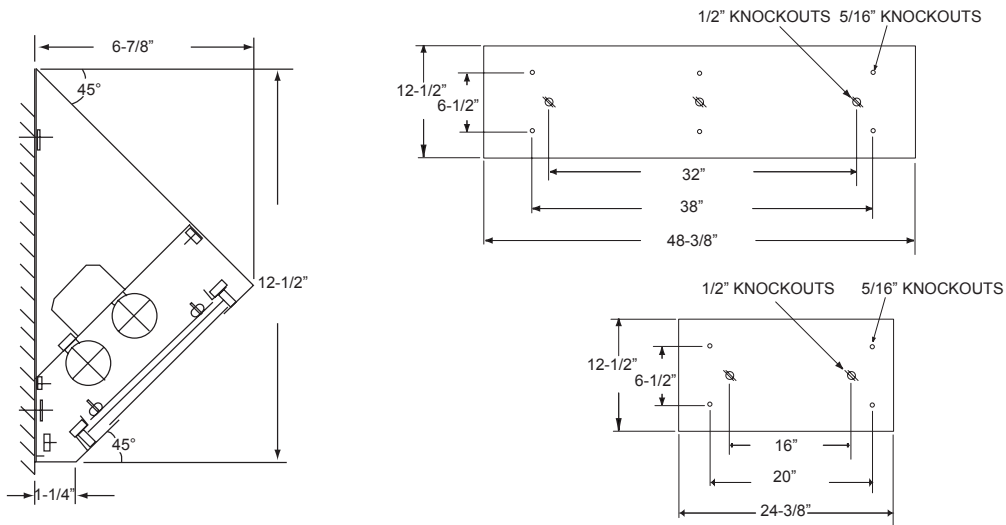

Photometry

Zonal Cavity Coefficient of Utilization

I.T.L. Test No. ITL 37586, Product Catalog Number:
MED-WST45-4-3-T5-EB10IS-3/C-SS-UNV
Lamps: Three 28WT5, each rated 3150

Floor Ceilings Walls(%)	80%				20% 70%				50%			
	70	50	30	10	70	50	30	10	70	50	30	10
0	48	48	48	48	47	47	47	47	44	44	44	44
1	43	40	38	36	41	39	37	35	37	35	34	34
2	38	34	31	28	37	33	30	28	31	29	27	27
3	35	30	26	23	33	29	25	23	27	24	22	22
4	32	26	22	19	30	25	22	19	24	21	18	18
5	29	23	19	16	27	22	18	15	21	18	15	15
6	26	20	16	13	25	20	16	13	18	15	13	13
7	24	18	14	11	23	17	14	11	17	13	11	11
8	22	16	12	10	21	16	12	10	15	12	09	09
9	20	14	11	08	20	14	11	08	13	10	08	08
10	19	13	10	07	18	13	09	07	12	09	07	07

**Candlepower
Distribution**

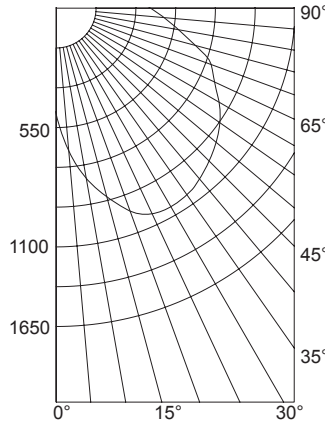

**Average Luminance
in Footlamberts**

Vertical Angles	Average Brightness	
	Norm	Para
45°	2564	827
55°	2585	690
65°	2561	665
75°	2397	539
85°	2025	258

Lumin. Effi.	Spacing Cross	Maint. Factor
41.0%	2.8	85%

Options

Antimicrobial: Agion™ Antimicrobial protection using silver technology inhibits bacterial colonization on metal interior and exterior surfaces. Agion™ antimicrobial FDA recognized and EPA registered, meeting all applicable EPA standards.



.125 Prismatic Acrylic
Lens Standard