

# VSM SERIES

SURFACE MOUNT

# INSTITUTIONAL/BEHAVIORAL



Specifier's Reference	
Project Name	Type
Catalog No.	
Comments	

- **Listings/Certifications:** ETL (US/Canada) Wet location listed

## Specifications

- **Housing:** 16-gauge cold rolled steel housing with spot welds for strength.
- **Gasket:** Closed cell neoprene gasketing between lens and housing.
- **Lens:** Standard .125" thick injection molded polycarbonate with frost finish.
- **Reflector:** White powder coated prime steel with 93% reflectance.
- **Fasteners:** Stainless Allen head center pin reject.
- **Lamps:** 32W T8 lamps supplied by others.
- **Ballasts:** Standard universal voltage 120V through 277V electronic 90% power factor <10% THD. Other ballast options available.
- **Finish:** Standard baked white polyester powder coat paint finish. Optional AgION™ antimicrobial finish available.

## Ordering Information

Example: **VSM - 232 - 2 - F1 - SS - UNV**

Series	Lamps	Ballast Type	Fasteners	Options	Voltage
<b>VSM</b>					
	<b>-132</b> One F032 T8 Lamps	<b>-EB10IS</b> Electronic Ballast <10% THD Instant Start	<b>-F1</b> Allen Head - center pin reject, standard	<b>-EMG1</b> 1-Lamp Emergency Power Pak	<b>-UNV</b>
	<b>-232</b> Two F032 T8 Lamps	<b>-SB</b> Specified Ballast	<b>-SF</b> Specified Fastener	<b>-SS</b> Stainless Steel Housing with Brushed Flange, Brushed Stainless Steel Door	<b>-347V</b>
				<b>-AL</b> Aluminum Housing, Aluminum Door	
				<b>-AG</b> AgION™ Antimicrobial Protection in Powder Coat Paint	
				<b>-GLR</b> GLR Fusing	

Note: Contact Factory For Additional Configurations.

**Morlite**  
TOUGH SITES ..... TOUGH LITES

1805 Pittsburgh Ave, Erie, PA 16502 • 800-865-5954 • Fax 800-667-9959



**Dimensions & Mounting**

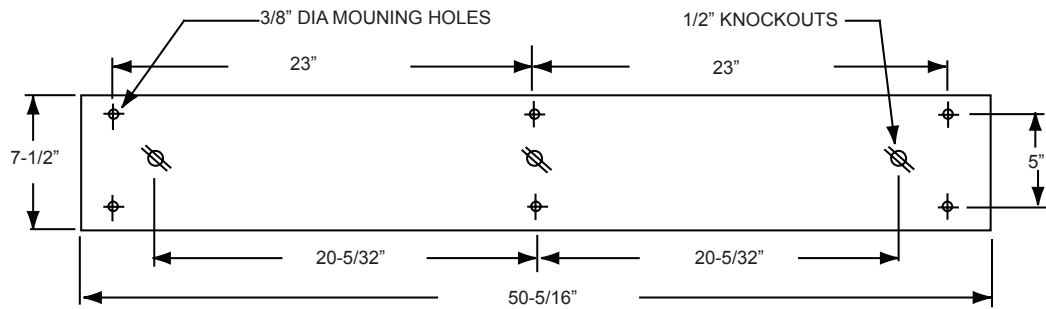
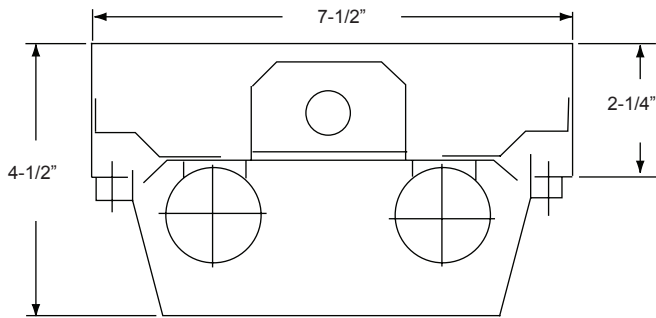

**Photometry**

**CONTACT FACTORY FOR PHOTOMETRICS**

**Options**

**Antimicrobial:** Optional Agion™ Antimicrobial protection using silver technology inhibits bacterial colonization on metal interior and exterior surfaces. Agion™ antimicrobial FDA recognized and EPA registered, meeting all applicable EPA standards.

Closed Cell  
Neoprene Gasket  
Standard

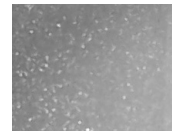
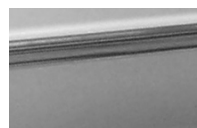

.125 injection molded  
polycarbonate lens  
with frosted finish